

Rocky Mountain Power
Exhibit RMP___(RAV-1SR)
Docket No. 17-035-40
Witness: Rick A. Vail

BEFORE THE PUBLIC SERVICE COMMISSION
OF THE STATE OF UTAH

ROCKY MOUNTAIN POWER

Exhibit Accompanying Surrebuttal Testimony of Rick A. Vail

RFP Shortlist Network Upgrades

May 2018

May 7, 2018_v5

At the Aeolus Substation, to support the Ekola Flats Wind project the following network upgrades area required.

- One (1) 230 kV 3000 ampere breaker and line position with associated switches at Aeolus substation

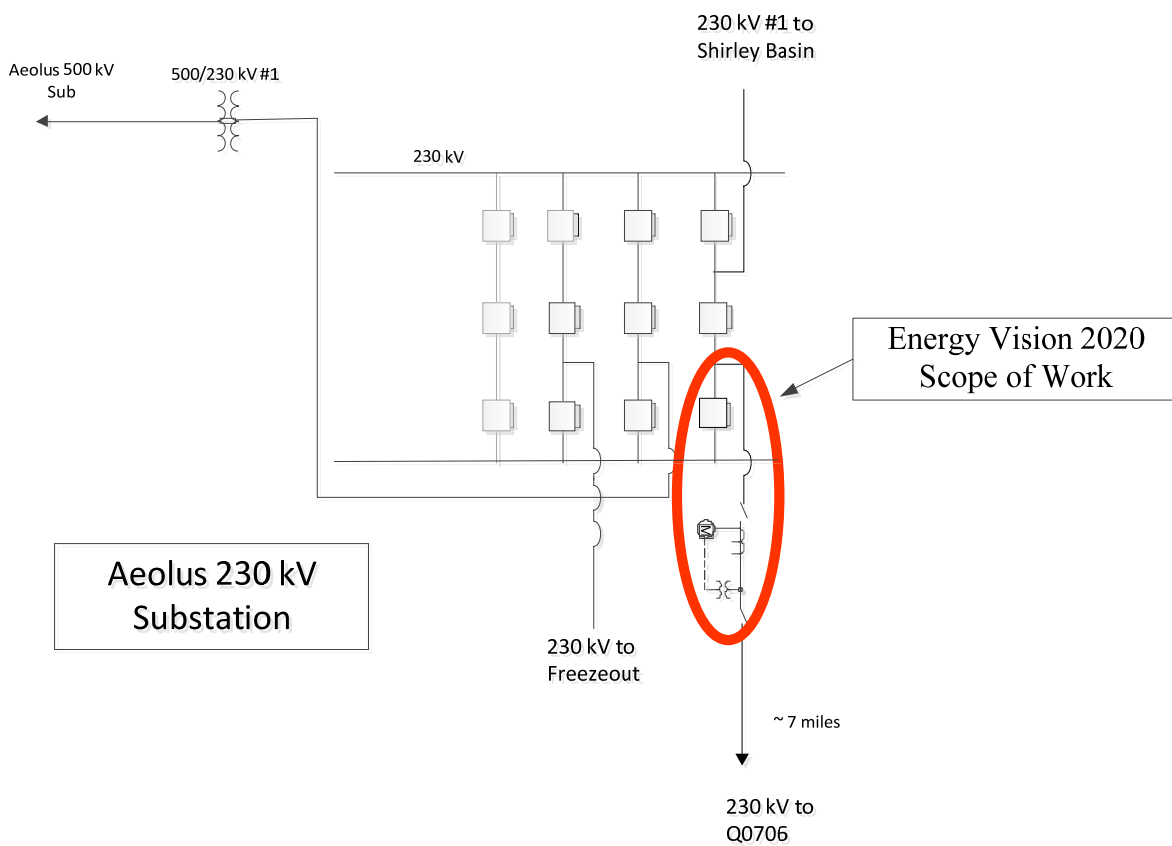

At the Shirley Basin Substation, to support the inclusion of TB Flats I wind project the following network upgrades are required:

- A new bay, five (5) new 3000 ampere 230 kV breakers, two line terminations with associated switches
- Construction of a new approximately 16.5-mile Shirley Basin – Aeolus 230 kV #2 line

At the Aeolus substation the following network improvements are required:

- Addition of one (1) new 230 kV breaker, line termination and associated switches
- Inclusion of the project in the Aeolus RAS generation dropping scheme

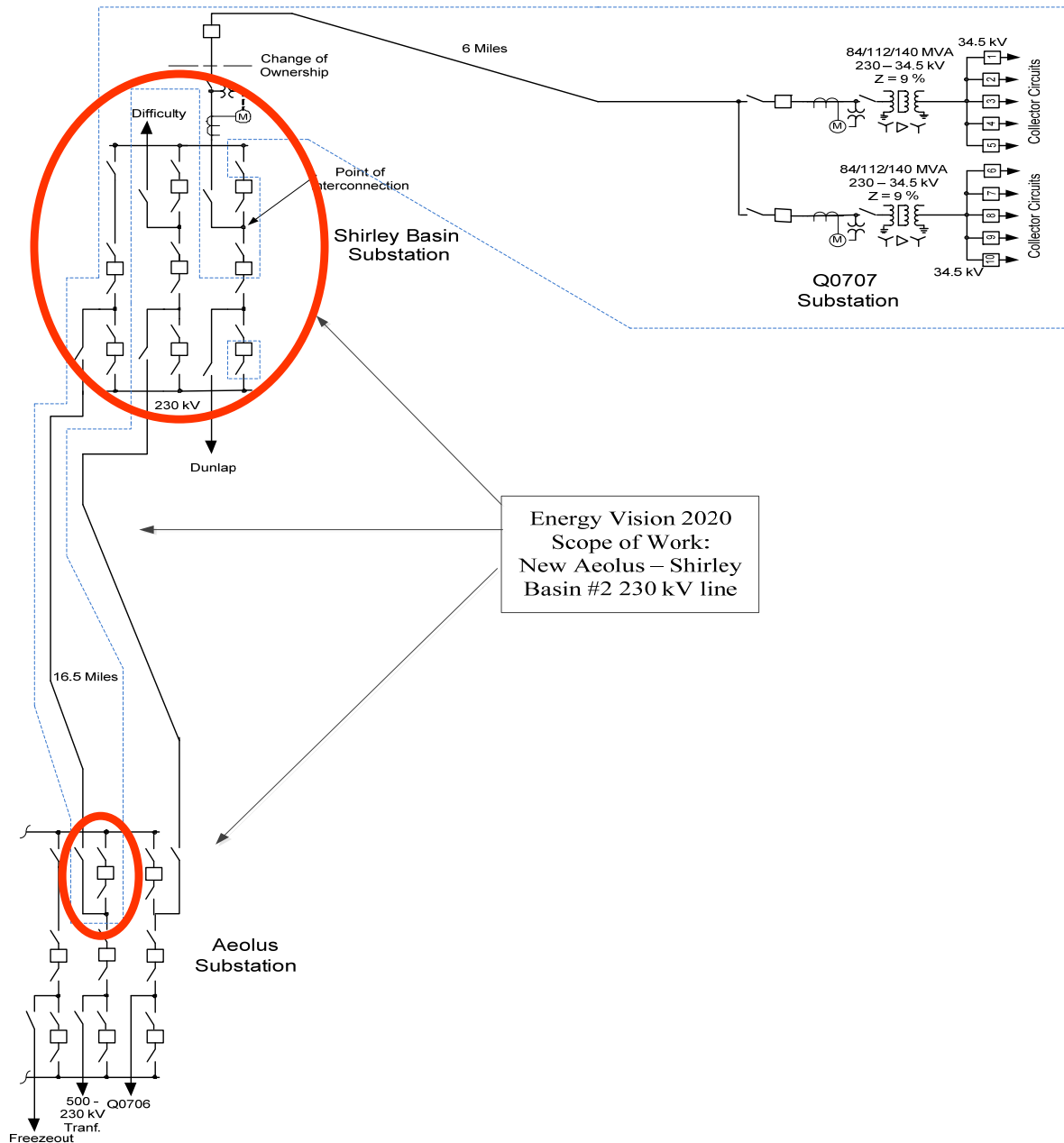

At the Shirley Basin Substation, to support the inclusion of TB Flats II wind project the following network upgrades are required:

- Expansion of the Shirley Basin 230 kV switchyard on the east side of the substation with a new bay.
- Two (2) 230 kV 3000 ampere breakers, line termination and associated switches
- Inclusion of the project in the Aeolus RAS generation dropping scheme

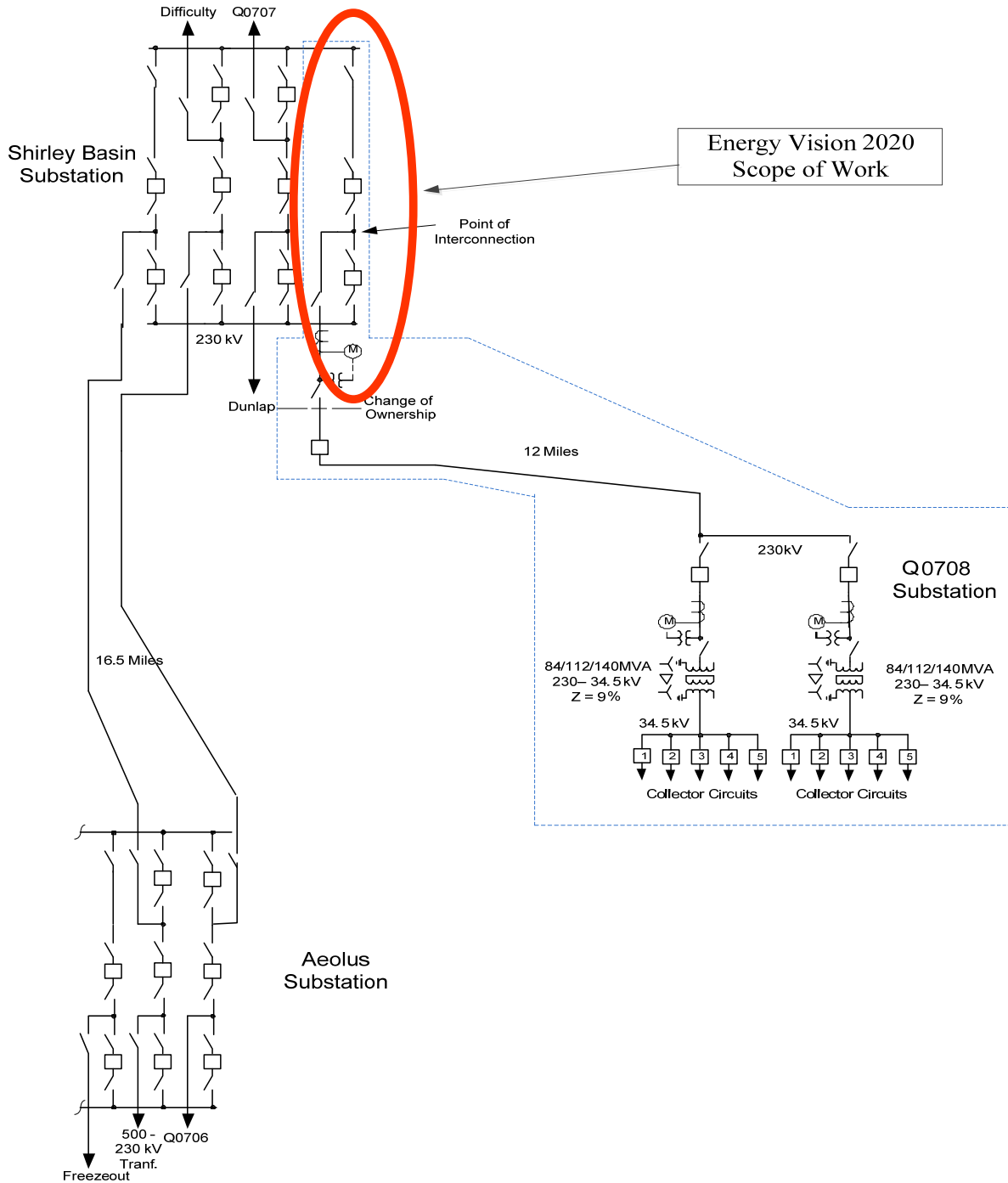

At Windstar substation, to support the inclusion of Cedar Springs I wind project the following network upgrades are required:

- Two (2) 230 kV 3000 ampere breakers and two line terminations with associated switches

At Freezeout substation to support the inclusion of the Cedar Springs I wind project the following network upgrades are required:

- Add one new bay and four (4) 230 kV (3000 ampere) breakers along with associated switches (staged in two bays) for re-termination of lines associated with the Aeolus – Freezeout – Standpipe 230 kV line rebuild.

Rebuild the Aeolus – Freezeout – Standpipe 230 kV line ~ 15 miles

Rebuild the Shirley Basin - Aeolus 230 kV #1 line ~ 16 miles

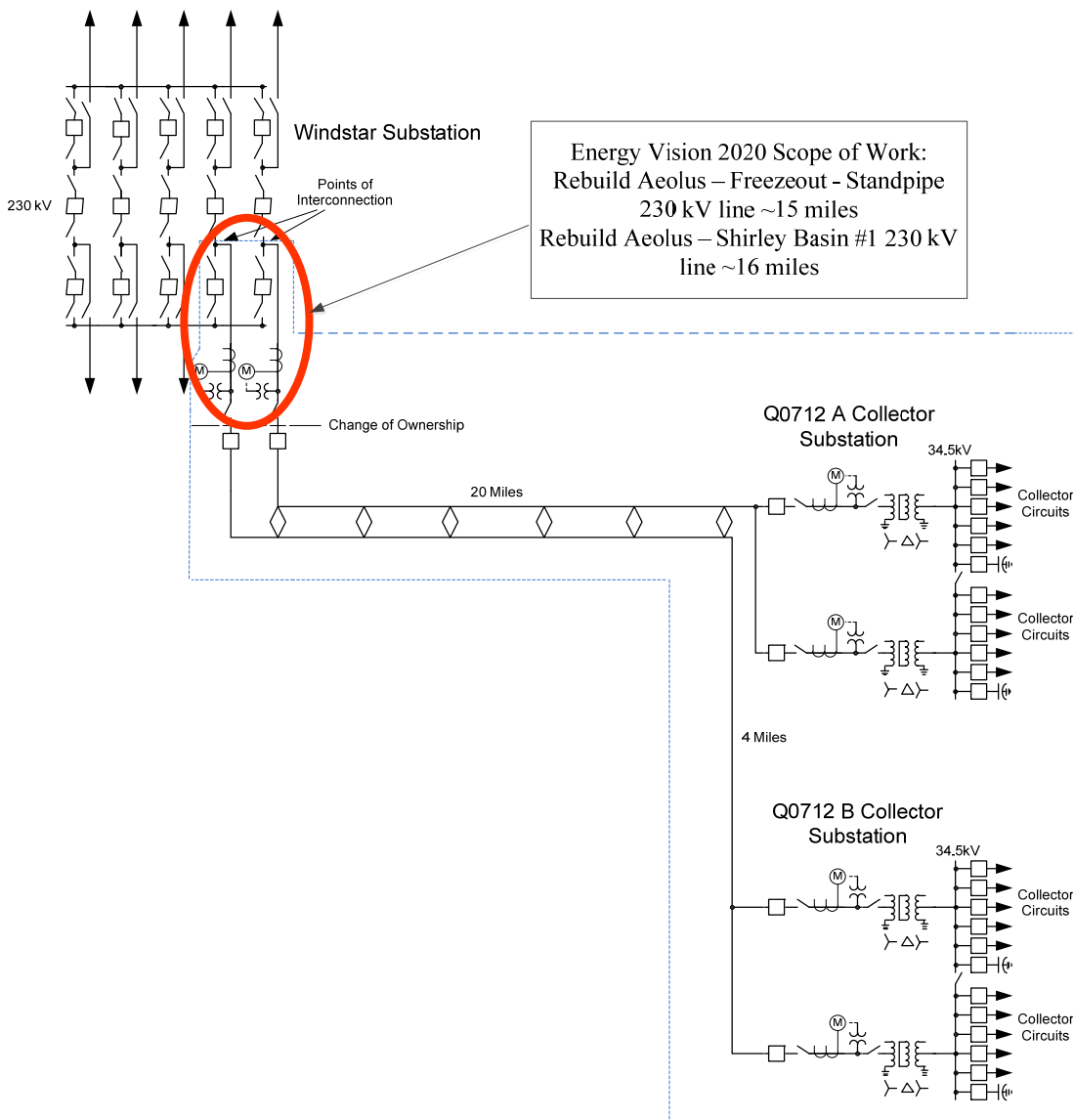

Freezeout Substation

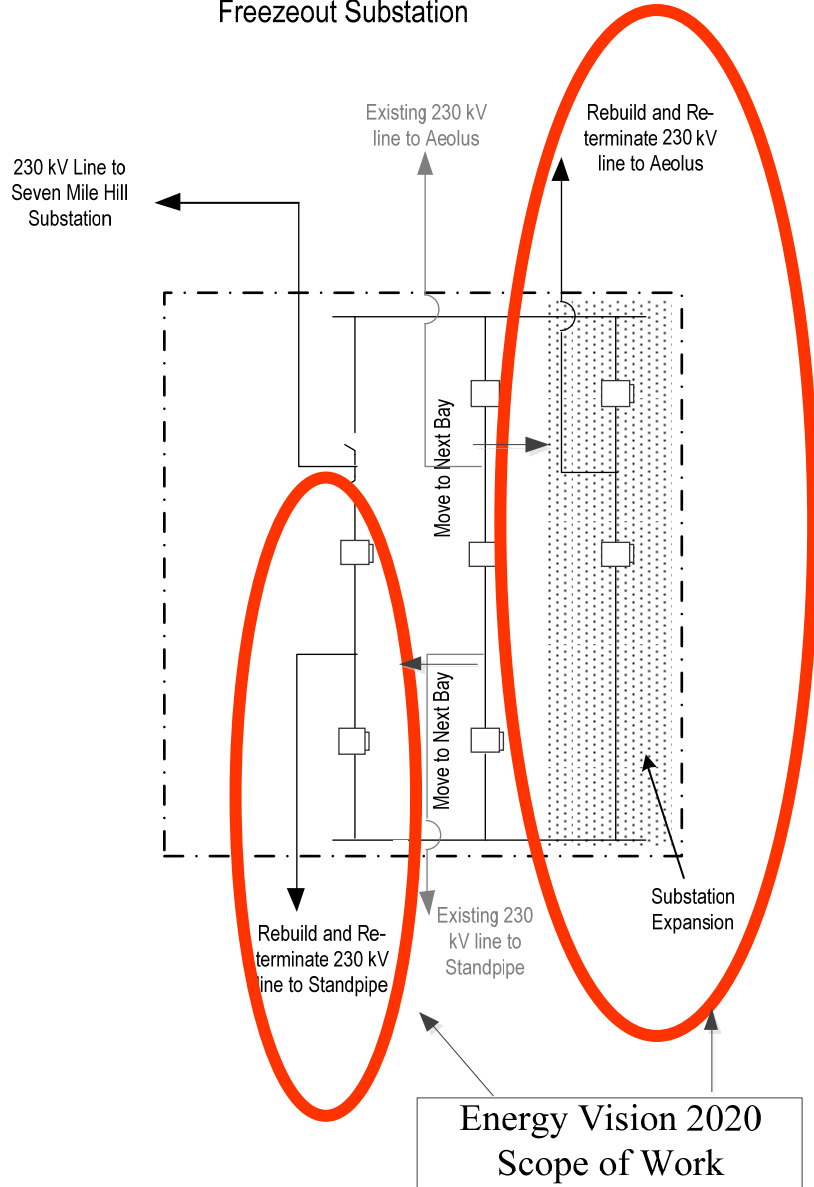

D.2 Project Facilities:

D.2 Project Transmission Facilities:

- Addition of the Aeolus 500/230 kV autotransformer
- Addition of the Aeolus – Anticline 500 kV line (~138 miles)
- Addition of the Anticline 500/345 kV autotransformer
- Addition of the Anticline – Bridger 345 kV line (5 miles)

Southeast Wyoming – Network Upgrades

- Loop the Shirley Basin – Freezeout 230 kV line into Aeolus 230 kV
- Add the Aeolus – Shirley Basin 230 kV #2 line (~16 miles) [Q0707]
- Rebuild the Aeolus – Shirley Basin 230 kV #1 line (~16 miles) [Q0712]
- Rebuild the Aeolus – Freezeout - Standpipe 230 kV line (~15 miles) [Q0712]
- Add Latham SVC

A drawing depicting all new D.2 Project network transmission facilities east of Jim Bridger Power Plant is provided below:

