

Rocky Mountain Power
Exhibit RMP__(SAB-10)
Docket No. 10-035-89
Witness: Stefan A. Bird

BEFORE THE PUBLIC SERVICE COMMISSION
OF THE STATE OF UTAH

ROCKY MOUNTAIN POWER

Exhibit Accompanying Direct Testimony of Stefan A. Bird

Dunlap I Wind Project Facilities Study Report

August 2010

Large Generator Interconnection

Facilities Study Report

**PacifiCorp Commercial & Trading
Dunlap Ranch Phase I LGI**

Proposed Interconnection
**To PacifiCorp's existing
Miners – Difficulty 230 kV transmission line**

January 22, 2009

TABLE OF CONTENTS

1.0	Description of the Project	1
2.0	Scope & Objectives.....	1
3.0	Scope of Work	1
3.1	Facilities Analysis Results	1
3.1.1	Collector Station	2
3.1.2	Radial Interconnection Line.....	5
3.1.3	Point of Interconnection Substation.....	6
3.1.4	Other Substations / Remote Sites.....	9
3.1.5	Communications Specifications [past the point of interconnection]	9
4.0	Cost Estimate	11
5.0	Schedule.....	12

1.0 Description of the Project

PacifiCorp C&T (“Interconnection Customer”) has proposed interconnecting ninety-nine MW of new generation to PacifiCorp’s (“Transmission Provider”) existing Miners – Difficulty 230 kV transmission line. The wind farm will be named Dunlap Ranch Phase I (“Project”) and will consist of sixty-six General Electric 1.5 MW SLE wind turbine generators.

The requested commercial operation date for the Project is September 31, 2009.

The Interconnection Customer has elected to have the interconnection studied as an *Energy Resource (ER)*.

Transmission Provider has assigned the Project Queue “Q0203”.

2.0 Scope & Objectives

The objective of the facilities study is to:

- Complete a facilities analysis, which shall specify and estimate the cost of equipment, engineering, procurement, and construction required to address issues as outlined in the system impact study, and
- Provide a scope of work and an estimated cost and schedule for completing the scope of work.

3.0 Scope of Work

3.1 Facilities Analysis Results

The new point of interconnection substation for the Q0203 generating facility will be located approximately fifteen (15) miles north of the Freezout 230 kV substation on the existing 230 kV Miners-Difficulty line. The 230 kV line will be looped in and out of the substation. The substation will be designed and constructed as a six (6) breaker ring bus with only three (3) breakers installed for this project. The Interconnection Customer will construct a nine (9) mile long 230 kV transmission line to the Q0203 collector station.

The following is a one line diagram for this system:

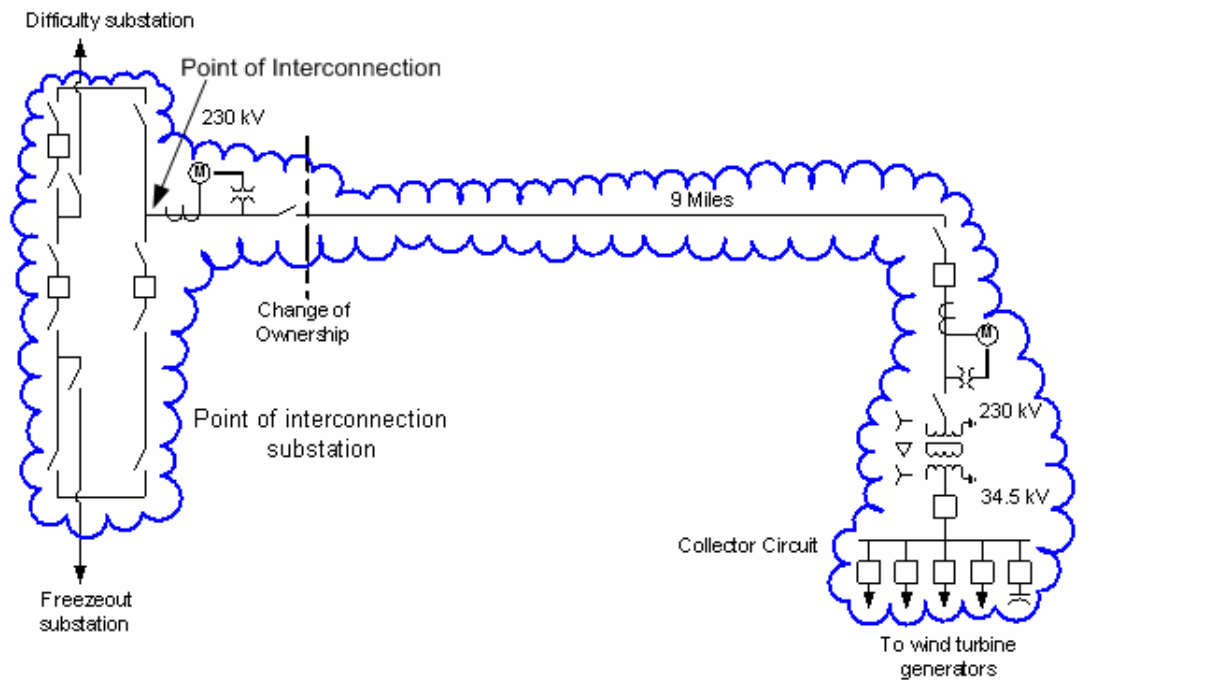

Figure 1: System one line diagram

3.1.1 Collector Station

Work to be completed by the Interconnection Customer

- Engineer, procure, and construct all facilities required for the Q0203 collector station except for those common facilities/components indicated as supplied by the Transmission Provider. The Interconnection Customer shall submit, on forms provided by the Transmission Provider, information specific to equipment designed, purchased, and installed by the Interconnection Customer that will be owned and maintained by the Transmission Provider. The completed forms are to be returned to the Transmission Provider's project manager or designated representative.

- Install a 242 kV, 2000A circuit breaker at the collector station for connection to the 230 kV transmission line. The Transmission Provider will review the Interconnection Customer's specifications for the breaker to ensure compatibility with the Transmission Provider's control and protection schemes.
- Design, purchase, and install the revenue metering system. This includes instrument transformers, junction boxes, and secondary lead conductors. The specifications for the metering design package will be identical to the point of interconnection metering system.
- Design, procure, and install the raceways for the metering secondary leads based on design data supplied by the Transmission Provider. Raceways shall be a minimum of 3" conduit; larger if dictated by the length of the metering leads. Transmission Provider will supply the metering current and voltage secondary leads.
- Provide space in the collector station control building for installation of the Transmission Provider owned and maintained panels and racks. Front and rear access will be required for this equipment.
- The following equipment, installed in the Interconnection Customer's collector station will be owned and maintained by the Transmission Provider: remote terminal unit (if used in lieu of data concentrator), line protection panel, and revenue metering panel, revenue metering transformers, fiber optic termination panels for fiber between the collector and point of interconnect substations.
- Provide power supplies for common equipment at configurations and voltages specified by the Transmission Provider.
- Design, purchase, and install the necessary splice boxes, patch panels, and racks required for terminating the OPGW and ADSS fiber cable installed between the Q0203 collector station and the point of interconnection substation. Fiber optic cable and termination panels will be owned by the Transmission Provider.
- Design, purchase, install, and terminate ADSS fiber optic cable from the fiber optic splice box located on the final 230 kV transmission line dead-end structure into the collector station control building in an underground raceway. The raceway from the splice box (3" conduit minimum) terminates in a fiber optic patch panel in the control building.

- Install a GE D20 remote termination unit designed, procured and maintained by the Transmission Provider or; Interconnection Customer may design, purchase, install, and maintain a data concentrator digital communications system. This links the collector station with the Transmission Provider's remote terminal unit located in the point of interconnection substation control building. This digital link will use DNP-3.0 (preferred) or Modbus protocol, (to be decided later).
- Terminate all field I/O connections on the remote termination unit required to provide data and control in accordance with safe system operation and in compliance with the Interconnection Agreement. Transmission Provider will complete wiring of outputs to the fiber communications system.
- Terminate the fiber cable installed between the collector stations and the point of interconnection substation and perform continuity and final testing to ensure installation meets specifications and standards provided by the Transmission Provider.
- Supply a dialup phone line or equivalent communications path for retail sales metering and generational accounting via the MV-90 translation system. This may be provided by utilizing the Transmission Provider's digital communications system.

Work to be completed by the Transmission Provider

- Design and purchase the Q0203 collector station revenue metering panel.
- Provide a list of data inputs and outputs required for protection, control, and data collection in accordance with the interconnection agreement.
- Design, procure, own and maintain the remote terminal unit required for the collector station, (if data concentrator option is not used). Terminate all inter-panel wiring and final checkout and testing of the remote terminal unit.
- Supply all specifications required for common equipment to facilitate design of the collector station.
- Perform final checkout and testing/commissioning of the interconnecting line protection control and metering systems in the collector station.

3.1.2 Radial Interconnection Line

Work to be completed by the Interconnection Customer

- Interconnection Customer will obtain all necessary permits, easements, and rights of way for the construction of the 230 kV radial interconnection line from the point of interconnection substation to the Q0203 collector station.
- Design, procure, and construct a 230 kV transmission line from a full dead-end structure located at least 20 feet outside the point of interconnection substation fence to the Q0203 collector station approximately nine (9) miles to the North.
- Construct the sagged and properly tensioned last span into the point of interconnection substation.
- OPGW fiber optic cable will be installed on the new 230 kV interconnect line to the collector station. This cable will be used for the line protection systems and to communicate status and loading information back to the Transmission Provider's energy control center. This cable will be owned and maintained by the Transmission Provider.
- Terminate the OPGW fiber optic cable on the last structure of the 230 kV radial interconnection line outside the point of interconnection substation fence using an appropriate fiber optic splice box.
- Terminate the OPGW fiber optic cable on the last structure of the 230 kV radial interconnection line outside the Q0203 collector station using an appropriate fiber optic splice box.

Work to be completed by the Transmission Provider

- Provide specifications for the installation and testing of the fiber optic cable installation between the collector substation and point of interconnection substation.
- Review the design of the last transmission line structure outside the point of interconnection substation to ensure compatibility with the substation termination structure.

3.1.3 Point of Interconnection Substation

Work to be completed by the Interconnection Customer

- Design, purchase, and install ADSS fiber optic cable from the fiber optic splice box on the final dead-end structure into the point of interconnection substation control building in an underground raceway. The raceway from the splice box (3" conduit minimum) connects to the raceway at the substation fence provided by the Transmission Provider.
- Interconnection Customer will be responsible for end to end checkout of the installed fiber optic cable circuitry between the collector station and point of interconnection substation. Final checkout and acceptance shall be in accordance with the Transmission Provider's standards and specifications.
- Obtain all necessary permits, lands, rights of way and easements required for the construction and continued maintenance of the new point of interconnection substation. All easements and permits will be recorded in the name of the Transmission Provider and will be on forms acceptable to the Transmission Provider. All easements and rights of way will be obtained for durations acceptable to the transmission provider. Includes all permits\easements for ingress and egress. Minimum land dimensions for substation property 400'x400'.

Work to be completed by the Transmission Provider

- Design, procure, and construct a new 230 kV switching substation to allow for the connection of the Q0203 Project to PacifiCorp's Miners-Difficulty 230 kV transmission line. The new substation is to be designed and constructed as a six (6) breaker ring with only three (3) breakers installed for this project. The entire facility is to be fenced and will have two (2) 24' doublewide gates and one (1) personnel access gate.
 - A list of the major equipment required is as follows:
 - 3 – 242 kV, 2000A circuit breaker
 - 9 – 230 kV, 2000A TPST, vertical break, manually operated switch
 - 3 – 230 kV, 2000A TPST, vertical break, manually operated switch equipped with grounding blades
 - 9 – 144 kV MCOV surge arresters
 - 6 – 230 kV CCVTs
 - 3 – 230 kV CT/VT combination metering units
 - 1 – 18' x 27' control building
 - 1 – 125V D/C, 100AH battery system with a 2 step, seismic zone 4 battery rack
 - 1 – 120/208/240V A/C, 130VD/C, 16 amp battery charger.

- Design, purchase, and install an underground raceway (3" conduit minimum) from the new point of interconnection control building to a point just outside the substation fence line for the installation of the ADSS cable by the Interconnection Customer.
- Install PLC path between the new point of interconnect substation and Difficulty substation.
- Design, procurement, and installation of all equipment required to connect the Q0203 generation and transmission system via the point of interconnection substation. This excludes installation and final checkout of the fiber optic cable communications system.

3.1.3.1 Transmission Specifications

Work to be completed by the Interconnection Customer

- No work required.

Work to be completed by the Transmission Provider

- Transmission modifications required for energy resource interconnection service are limited to the addition of the new 230 kV interconnecting station connected to the Freezout- Difficulty 230 kV line, with the line looped in and out of the station.
- The Transmission Provider will design, procure, and install the 1.25 mile loop-in and loop-out transmission line from the point of interconnection substation to the Freezout-Difficulty 230 kV line. The loop-in and loop-out line will consist of two new dead-end structures and twenty 230 kV structures.

3.1.3.2 Protection and Control Specifications

Work to be completed by the Interconnection Customer

- Install all protection and control equipment in the Q0203 collector station.

Work to be completed by the Transmission Provider

- Design, and procure transmission line protective relays for line fault detection at the new point of interconnection substation for the protection of the lines to the Q0203 collector station, and the Difficulty and Aeolus or Freezout substations.
- Design, purchase, and install a relay for under/over voltage and over/under frequency protection of the system at the point of interconnection substation. If an out of operating range condition occurs, a signal will be sent over the fiber optic cable to trip open all of the Q0203 34.5 kV line breakers at the collector station.

- Design and install necessary generator tripping/load reduction schemes that will be required to ensure system stability during system disturbances.
- Provide a list of data points required for protection, control and data collection in accordance with the Interconnection Agreement.
- Perform final checkout and testing/commissioning of the protection, and control systems in the Q0203 collector station.
- Establish PLC to path to Difficulty substation.
- Remove PLC equipment at either the Aeolus or Difficulty substations.

3.1.3.3 Metering Specifications

Work to be completed by the Interconnection Customer

- Design, purchase, and install the revenue metering system for the Q0203 collector station. This includes instrument transformers, junction boxes, and secondary lead conductors. The specifications for the metering design package will be identical to the Point of Interconnection metering system.
- Design, procure, and install the raceways for the metering secondary leads based on design data supplied by the Transmission Provider. Raceways shall be a minimum of 3” conduit; larger if dictated by the length of the metering leads. Transmission Provider will supply the metering current and voltage secondary leads.
- Supply a dial-up phone line, or equivalent communications path, for retail sales and generation accounting via the MV-90 translation system. This may be provided utilizing the Transmission Provider’s digital communication system.

Work to be completed by the Transmission Provider

- Design, procure, install, and own the point of interconnection revenue metering equipment. The metering will be designed for the total net generation of Phase I.
- Transmission Provider will design, procure, and own the revenue metering panel for the Q0203 collector station. The metering will be designed for the total net generation of Phase I and be mounted on the high side of the step-up transformer.

- Transmission Provider will supply the metering current and voltage secondary wire leads along with design specifications for the lead wiring connections between the metering panels and instrument transformers.
- Transmission Provider will perform final checkout and testing/commissioning of the metering system in the Q0203 collector station.

3.1.4 Other Substations / Remote Sites

Work to be completed by the Interconnection Customer

- No work required.

Work to be completed by the Transmission Provider

- It is assumed that the Aeolus substation is completed with communications to WECC and SOCC. With this scenario OPGW fiber is to be installed between the Q0203 point of interconnection substation and Aeolus substation. If Aeolus is not constructed OPGW fiber is to be installed from the Q0203 point of interconnection substation to Freezout substation. The line protection relays at Aeolus substation will be compatible with the Q0203 line protection relays.
- Remove the power line carrier transmitter/receiver at Aeolus substation. Power line carrier will continue to be the mode of communication for the line relays on the Difficulty substation line.

3.1.5 Communications Specifications [past the point of interconnection]

Work to be completed by the Interconnection Customer

- Install OPGW fiber optic cable on the new 230 kV line from the Q0203 collector station to the point of interconnection substation.
- Install ADSS fiber optic cable from splice boxes on the final dead-end structures at the point of interconnection substation and Q0203 collector station into the control buildings and terminate in fiber optic patch panels.
- Install a GE D20 remote termination unit designed, procured and maintained by the Transmission Provider or; Interconnection Customer may design, purchase, install, and maintain a data concentrator digital communications system consisting of a data concentrator, fiber modules, and multiplexer at the collector station and provide DC power to units.

Work to be completed by the Transmission Provider

- Install an RTU, fiber modules, and multiplexer at the Q0203 point of interconnection substation.
- Install OPGW cable between the new point of interconnection substation and the existing 230 kV substation, (either to Aeolus or Freezout).
- Remove existing PLC equipment at either Aeolus or Freezout and convert to fiber communications.
- Install PLC in new point of interconnection substation to Difficulty substation.
- Design, purchase, and install all materials to ensure a complete and reliable path of communication/control between the customer generation/interconnection facilities and the transmission providers control and data acquisition centers.
- The following remote sites will require communication work: WECC and SOCC (computer centers) for dispatch control of this site.

4.0 Cost Estimate

Direct Assigned Costs

Q0203 Collector Substation – engineering, design, procurement and installation of metering, communication and protection and controls equipment.	\$327,000
Point of interconnection substation - engineering, design, procurement and installation of the dead-end structure.	\$249,000
Point of interconnection substation - engineering, design, procurement and installation of metering equipment.	\$294,000
<u>Subtotal Direct Assigned Costs</u>	<u>\$ 870,000</u>

Network Upgrades

Point of interconnection substation – new 230 kV switching station with property.	\$1,744,000
Point of interconnection substation – 230 kV station control house.	\$477,000
Point of interconnection substation – 230 kV three breaker line position.	\$3,755,000
Point of interconnection substation – 230 kV line position, complete breaker bay into a full ring bus.	\$596,000
Point of interconnection substation – one mile access road.	\$577,000
Transmission line loop - Engineering, design, procurement and installation of twenty 230 kV transmission structures. Right of way not included.	\$1,911,000
Aeolus Substation network upgrade.	\$26,100
Difficulty substation network upgrade.	\$8,900
Point of interconnection substation - engineering, design, procurement and installation of communication equipment.	\$172,000
Aeolus substation - engineering, design, procurement and installation of communication equipment.	\$598,000
Salt Lake City Control Center - point of interconnection substation - engineering, design, procurement and installation of communication equipment.	\$9,000
Wyoming Control Center - engineering, design, procurement and installation of communication equipment.	\$8,000
Difficulty substation - engineering, design, procurement and installation of communication equipment.	\$23,000
Freezout substation - engineering, design, procurement and installation of communication equipment.	\$8,000
<u>Subtotal Network Upgrades</u>	<u>\$9,913,000</u>

Total Cost: Interconnection Service (Interconnection Only) **\$10,783,000**

5.0 Schedule

This schedule is contingent upon Transmission Provider receiving the signed Interconnection Agreement and financial security by January 1, 2009. If the signed agreement and security are not received by that date there will be, at a minimum, a day for day slip in the entire schedule.

Initiating task	Date
Execute interconnection agreement	January 1, 2009
Engineering & procurement commences	Feb. 1, 2009
Engineering design completed	August 1, 2009
Construction begins	September 1, 2009
Customer equipment, power supply, communication work complete.	March 1, 2010
Generator step-up transformer receives back feed power	May 1, 2010
Generations testing	July 30, 2010
Commercial operation	September 30, 2010

Please Note: Dates indicated reflect milestones for tasks to be performed by the transmission provider. Interconnection customer will be required to have installed all equipment, power supplies and established communications circuits by March 1, 2010 to allow time for final checkout and testing of protection, control and data acquisition circuits prior to back feed.