

ZG 64I Padvault—Shallow, 7' × 7' (84" × 84")

1. Scope

This specification outlines the minimum requirements for shallow 7' × 7' (84" × 84") vault to be used for pad mounted equipment when there is no potential for the use of 1000 kcmil cable. The specification applies to all shallow 7' × 7' (84" × 84") vaults installed by the company, contractors, customers, or suppliers.

2. Applicable Documents

The latest revisions of the documents, standards, codes and requirements listed in Section 2.1, Company Material Specifications, and 2.2, Codes and Standards, in effect on the date of invitation to bid apply to the extent specified herein.

2.1. Company Material Specifications

ZG 301 *General Equipment Base and Enclosure Requirements*

ZG 311 *Concrete Requirements*

ZG 811 *Full Traffic Cover and Frame Assembly*

2.2. Codes and Standards

ASTM C857 A-16 (2007)

AASHTO H-20 (for vaults beneath roadways)

ASTM C857 A-8 (for vaults beneath incidental light truck traffic)

IEEEEC2, *National Electric Safety Code (NESEC)*

3. Definitions

Company. Refers to PacifiCorp

PacifiCorp. Refers to Pacific Power and Rocky Mountain Power.

4. General

4.1. Application Information

This specification states material and construction requirements which are applicable only to shallow 7' × 7' (84" × 84") padvaults.

5. Applicable Stock Item Numbers

Materials being submitted for the following company stock item numbers are subject to evaluation according to the requirements in this specification.

5.1. Stock Item Numbers

7992787, PADVAULT, 7' × 7' (84" × 84"), FOR TYPE-3, 15 & 25KV, DF SWITCHGEAR

7992958, PADVAULT, 7' × 7' (84" × 84") , FOR 2.4-25 kV, 1000-2500 kVA TRANSFORMER

7992959, PADVAULT, 7' × 7' (84" × 84"), FOR 35 kV, 1000-2500 kVA TRANSFORMER

6. Design and Manufacturing Requirements

The purpose of a shallow 7' × 7' (84" × 84") vault is to provide an enclosure for cable pulling, large transformers, three-phase metering, and pad-mounted switching.

6.1. Vault Layout

Figure 1 and Figure 2 below show the assembled shallow 7' × 7' (84" × 84") vault layout with dimensions. Unless otherwise approved by company engineering, all dimensions and placement of hardware shall conform to those shown in Figure 1 and Figure 2.

6.2. Lifting Attachments

Enough lifting attachments shall be provided to ensure safe installation of all pieces at the site.

6.3. Pulling Attachments

Cable pulling attachments shall be installed opposite each set of TERM-A-DUCT banks, such that blocks may be attached for a straight cable pull. Pulling attachments shall have a minimum pullout strength of 6000 pounds. Attachments shall allow the attachment of a clevis with a one-inch diameter through-bolt. Pulling attachments may be designed by the manufacturer to meet these requirements.

6.4. Conduit Entrances

There must be six 6.63" and one 2.38" TERM-A-DUCT on opposite walls and twelve 6.63" and one 2.38" TERM-A-DUCT on the other opposite walls, as shown in Figure 2.

6.5. Incidental Traffic Access Door

One access door with an opening no greater than 24' × 60' , as specified in ZG 811, shall be included with the assembly.

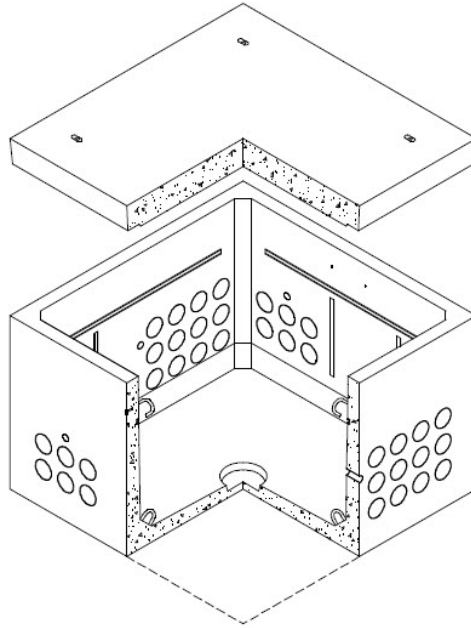

Figure 1—7' × 7' (84" × 84") Shallow Vault, Cutaway View

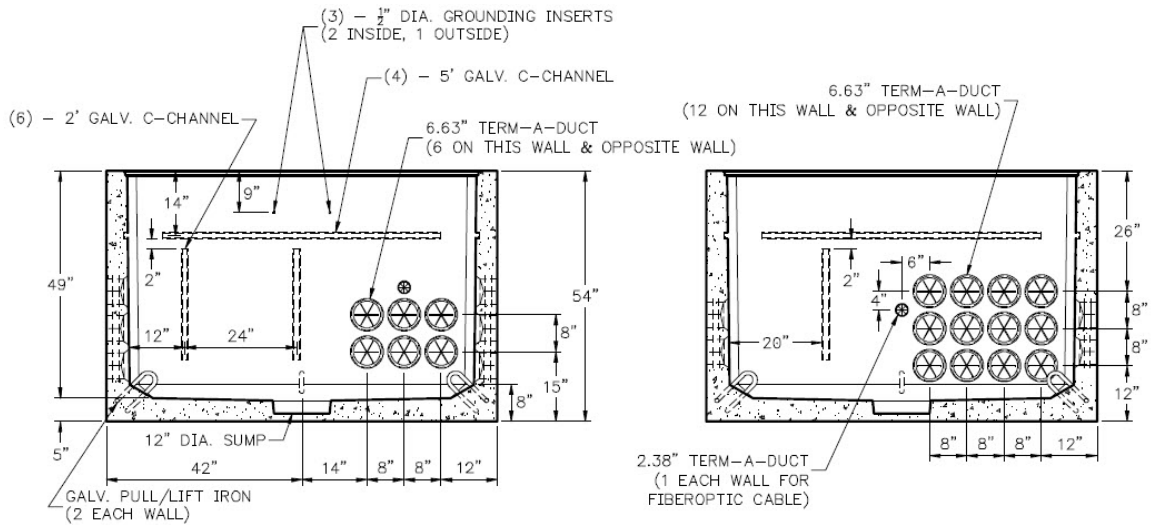

Figure 2—7' × 7' (84" × 84") Shallow Vault Layout

6.6. Padvault Top Layout for Type-3 Switchgear

Figure 3 shows the layout of the padvault lid for Type-3 switchgear.

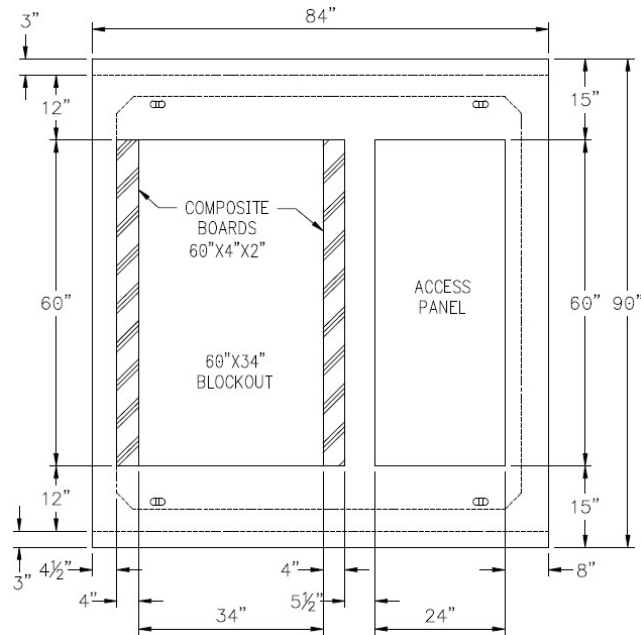

Figure 3—Padvault Pad Layout (SI# 7992787) for 15/25 kV, 600-Amp Type-3 Switchgear

6.7. Ground Grid

The vault shall be built with an internal, encased electrode in the vault enclosure meeting NESC 094.B.5. The electrodes shall be $\frac{3}{8}$ " steel rebar. The electrode shall be encased horizontally and run continuously around the vault section. The grounding system of the vault enclosure shall attach to "connection" inserts, made of high-bronze alloy and threaded to $0.5" \times 13\text{UNC}$. All grounding inserts shall have caps or plugs installed. The shallow $7' \times 7'$ ($84" \times 84"$) vault shall have two grounding inserts outside and four grounding inserts inside. The grounding inserts shall be located nine inches (9") from the top on the outside of the vault. One additional grounding insert shall be installed on the lid, close to the access door. See Figure 4 for the ground grid layout.

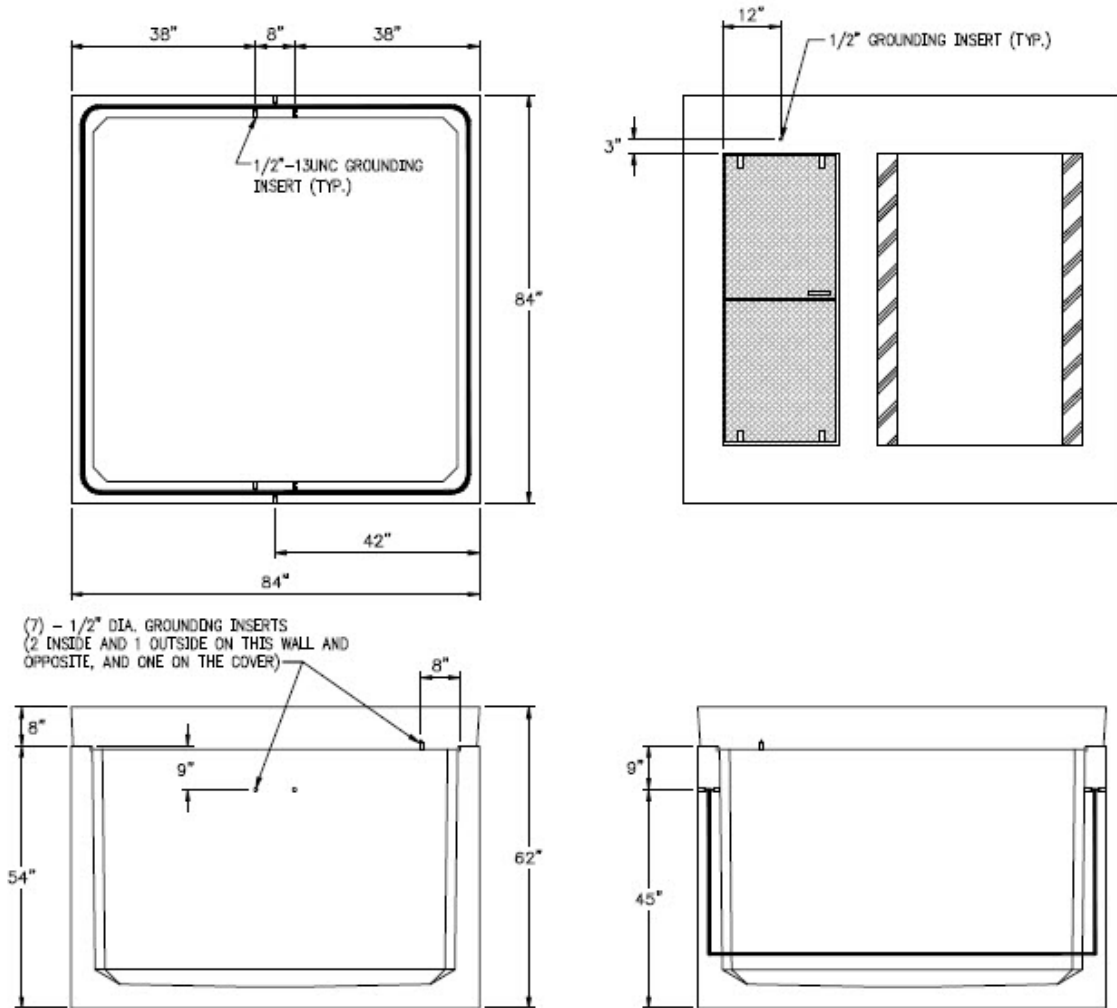

Figure 4—Ground Grid Layout for 7' × 7' (84" × 84") Shallow Vault

6.8. Installation

This unit shall be set at the site by the supplier. The contractor is responsible to ensure that all earth under the vault is compacted and leveled to no more than 2% slope prior to setting the vault. A clean gravel base under the pad may be necessary in areas where drainage is poor. The interface between the cover/frame assembly and the base should be sealed using a waterproof substance, such as tar or mastic. The top of the frame should be flush with final grade in pedestrian areas. Setting depth shall be determined by the local regulatory authority for full-traffic areas.

7. Testing

7.1. Test Compliance

Vaults submitted under this specification shall meet all tests and requirements contained in ZG 301 *General Equipment Base and Enclosure Requirements*, ZG 311 *Concrete Requirements*, and this specification. Vaults shall also comply with requirements in applicable national standards.

8. Issuing Department

The engineering standards and technical services department of PacifiCorp published this material specification. This material specification shall be used and duplicated only in support of company projects.